

Novel General Procedure for the Preparation of Homogeneous Nonionic Surfactants

Péter Sallay^{a,*}, László Farkas^a, Zoltán Szlovák^a, István Rusznák^a, Péter Bakó^a, Mohamed Ahmed^{a,1}, Antal Tungler^b, and Gabriella Fogassy^b

Departments of ^aOrganic Chemical Technology and ^bChemical Technology, Budapest University of Technology and Economy, Budapest, Hungary, H-1521

ABSTRACT: Homogeneous nonionic surfactants were produced by the ethoxylation of a selected unit of a homolog series. These particular products are of use for the analysis of nonionics and for the determination of surface characteristics. A new general method for the synthesis of homogeneous nonionic surfactants is described. Ethylene glycol monobenzyl ether was repeatedly reacted in Williamson synthesis (or esterified with acid chlorides in the first step), followed by hydrogenolysis with alkyl- or aralkyl alcohols, phenols, carboxylic acids, and amines. Homogeneous nonionics can be synthesized by this method, whereas the conventionally produced ones are usually inhomogeneous.

Paper no. S1295 in *JSD* 5, 353–357 (October 2002).

KEY WORDS: Ethylene glycol monobenzyl ether, homogeneous surfactants, Williamson synthesis.

Various surfactants (ionic, nonionic, and amphoteric) have played an increasingly important role in industry as well as in the household. Anionics are still widely used in spite of certain disadvantages. At present, the nonionics are increasing in popularity because of their prominent properties (e.g., inertness to water hardness, reduced inclination to foaming, adjustable hydrophilic-lipophilic balance, etc.). Ethoxylation is the principal reaction in the industrial syntheses of nonionics (1,2).

Ethoxylation (hydroxyethylation) is the reaction of ethylene oxide with a molecule having a mobile hydrogen

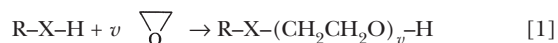

where R is an alkyl, aralkyl, or alkylphenyl group; X is an oxygen or nitrogen atom or a carboxylic group; and *v* is the number of the ethylene oxide molecules reacted (average degree of ethoxylation).

As all products of conventional ethoxylation always contain free hydroxyl groups (glycol monoethers or esters),

Abbreviations: IR, infrared; NMR, nuclear magnetic resonance; TLC, thin-layer chromatography; THF, tetrahydrofuran; TsCl, tosyl chloride. *To whom correspondence should be addressed at Budapest University of Technology and Economy, Department of Organic Chemical Technology, Budapest, Műegyetem rkp. 3, Hungary, H-1521.

E-mail: sallay.oct@chem.bme.hu

¹Present address: Benha University, Egypt.

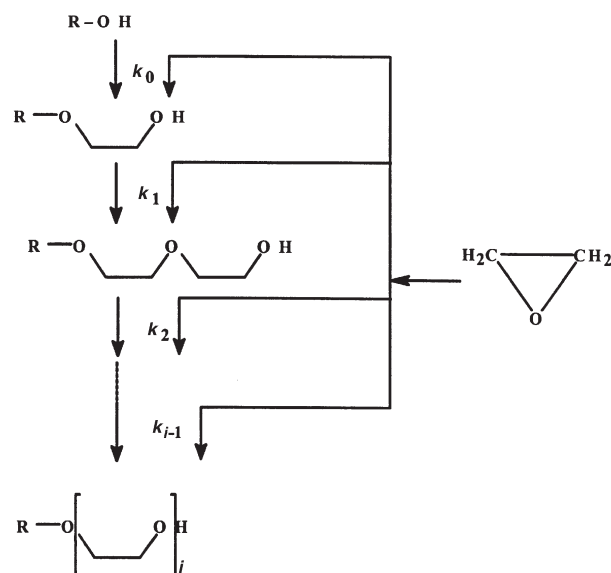

SCHEME 1

they can react with ethylene oxide in the same way. As the result of a consecutive series of competing reactions (Scheme 1), the product is always a mixture of homologs. This mixture is suitable for technical applications.

The molar mass distribution (and by this means the properties) of an ethoxylated product is controlled by its reaction conditions (catalysts, temperature, etc). Consequently, “tailor-made” surfactants can be produced under properly selected conditions. Occasionally (e.g., in the analysis of molar mass distribution or in the measurement of surface properties), the use of homogeneous nonionics is necessary. A homogeneous surfactant contains only identical ethoxylated polymers of a homolog series (3).

Many synthetic methods are used for the preparation of homogeneous surfactants, based either on the well-known Williamson synthesis (Eq. 2) (3) or, in the case of esters, on the acylation of ethylene glycol (Eq. 3) (4).

